

Service Time Analysis of a Distributed Medium Access Control Scheme

Hai Jiang, *Member, IEEE*, Ping Wang, *Member, IEEE*, Weihua Zhuang, *Fellow, IEEE*,
and H. Vincent Poor, *Fellow, IEEE*

Abstract—Distributed medium access control (MAC) is essential for a wireless network without a central controller. In previous work of the authors, a distributed MAC scheme has been proposed to achieve guaranteed priority and enhanced fairness performance. For a wireless network, the service time distribution at the MAC sub-layer is important for performance analysis (e.g., in terms of packet delay, packet dropping rate, and admission region) at the network layer, because the network layer performance is largely dependent on the high-order time-domain statistics of the service provided by the MAC sub-layer. This paper presents a service time distribution analysis of the previously proposed distributed MAC scheme. Specifically, the respective distributions of the node service time and the system service time are derived. Simulation results verify the accuracy of this analysis.

Index Terms—Performance analysis, medium access control, service time.

I. INTRODUCTION

IN a wireless network, the wireless medium is shared by all the nodes. To achieve efficient utilization of scarce radio resources, the access to the medium among all the nodes should be coordinated by *medium access control (MAC)*. MAC techniques can be loosely categorized into two groups: centralized and distributed. Centralized MAC is performed at a central controller (e.g., the base station in cellular networks). The central controller collects information from all the nodes and informs the nodes when and how they can access the wireless channel. On the other hand, in distributed MAC, each node determines its channel access time according to its observation of the channel and limited information exchanges with other nodes. Because of the advantages of scalability, distributed MAC is particularly suitable for wireless networks

without a central controller, for example, mobile ad hoc networks and wireless mesh backbone networks [1], [2]. In addition, although a wireless local area network (WLAN) may have a central controller (i.e., the access point), distributed medium access (i.e., distributed coordination function, DCF) is mandatory in current IEEE 802.11 standards.

It is challenging to achieve quality-of-service (QoS) (e.g., reception quality, delay/jitter bound, and fairness) using distributed MAC. The enhanced distributed channel access (EDCA) in the IEEE 802.11e [3] has been proposed to achieve relative service differentiation, in which nodes with smaller arbitration interframe space (AIFS) and/or smaller initial (CW_{\min}) and maximum (CW_{\max}) contention window sizes can be in an advantageous position in channel contention. However, no guaranteed priority is provided, and thus high priority traffic performance may be affected by a large volume of low priority traffic [4] [5]. In addition, although good long-term fairness has been observed with DCF and EDCA, their short-term fairness performance is poor due to the use of binary exponential backoff [6]. When a node transmits its packet successfully, its contention window size is reset to the initial value CW_{\min} . Its chance to win the subsequent contentions continues to be high, thus leading to short-term unfairness.

To solve the above problems, in [7] we have proposed a black-burst based MAC scheme that slightly modifies the EDCA. In this scheme, a higher priority traffic class can obtain guaranteed priority over a lower priority traffic class. Whenever there is higher priority traffic, lower priority traffic cannot get access to the medium. Thus this scheme is particularly effective in satisfying the delay requirements of real-time traffic. Furthermore, in each traffic class, the channel access time is distributed to all the nodes fairly in the short term. This is suitable for non-real-time data traffic supported by transmission control protocol (TCP), as the TCP performance degrades greatly over a short-term unfair channel access scheme [6]. Thus, our scheme is attractive for multimedia traffic support in distributed settings. In [7], we have derived the total throughput that can be provided by the MAC sub-layer. However, the analysis of throughput (or equivalently, a first-order statistic of service time) is not sufficient for the purpose of network design supporting multimedia traffic having heterogeneous QoS requirements. It is well accepted that higher-order statistics of the service time at the MAC sub-layer have significant effects on the higher layer performance such as packet delay experienced by voice/video and end-to-end throughput experienced by data with TCP. In other

Manuscript received June 6, 2007; accepted December 5, 2007. The associate editor coordinating the review of this paper and approving it for publication was Y.-B. Lin. This work was supported by the Premier's Research Excellence Award (PREA) from the Ontario Government, the Strategic Project (STPGP 336286 - 06) of the Natural Science and Engineering Research Council (NSERC) of Canada, a Postdoctoral Fellowship from NSERC of Canada, and the U.S. National Science Foundation under Grants ANI-03-38807 and CNS-06-25637.

H. Jiang is with the Department of Electrical and Computer Engineering, University of Alberta, Edmonton, Alberta, Canada T6G 2V4 (e-mail: hai.jiang@ece.ualberta.ca).

P. Wang is with the school of Computer Engineering, Nanyang Technological University, Singapore 639798 (e-mail: wangping@ntu.edu.sg).

W. Zhuang is with the Centre for Wireless Communications, Department of Electrical and Computer Engineering, University of Waterloo, 200 University Avenue West, Waterloo, Ontario, Canada N2L 3G1 (e-mail: wzhuang@bbr.uwaterloo.ca).

H. V. Poor is with the Department of Electrical Engineering, Princeton University, Princeton, New Jersey 08544, USA (e-mail: poor@princeton.edu).
Digital Object Identifier 10.1109/T-WC.2008.070606

TABLE I
SUMMARY OF IMPORTANT SYMBOLS USED.

Symbol	Definition
C_t	contention window stage of the target node
$\{CW_1, CW_2, CW_3\}$	contention window setting
m_1/m_2	numbers of nodes having contention window CW_1/CW_2
N	number of nodes in the network
n_1/n_2	number of non-target nodes having contention window CW_1/CW_2
$P_{m_1, m_2; k_1, k_2}$	probability that the system's first successful transmission leads the system to state (k_1, k_2) , given that the system starts from state (m_1, m_2)
$p_{C_t, n_1, n_2; x_t, x_1, x_2, x_3}$	probability that the transmission vector is (x_t, x_1, x_2, x_3) at the next event, conditioned on the current state being (C_t, n_1, n_2)
$p_{m_1, m_2; y_1, y_2, y_3}(i)$	probability that the transmission vector is (y_1, y_2, y_3) with the largest backoff timer value i at the next event, conditioned on the current state being (m_1, m_2)
$Q_{\text{node}}(N)/Q_{\text{system}}(N)$	probability generating function of the node/system service time when there are a total of N nodes
Q_{m_1, m_2}	probability generating function of the time from a state (m_1, m_2) to any state with a successful transmission
$T_{m_1, m_2; y_1, y_2, y_3}$	transition function of the transmission vector (y_1, y_2, y_3) from state (m_1, m_2)
T_x	information packet exchange dialogue duration
$t_{C_t, n_1, n_2; x_t, x_1, x_2, x_3}$	average time duration of the transmission(s) with the transmission vector (x_t, x_1, x_2, x_3) at the next event conditioned on the current state being (C_t, n_1, n_2)
t_{slot}	slot duration
x_t	number of transmission from the target node
$x_1/x_2/x_3$	number of transmissions from non-target nodes having contention window $CW_1/CW_2/CW_3$
$y_1/y_2/y_3$	number of transmissions from nodes having contention window $CW_1/CW_2/CW_3$
$\psi(m_1, m_2)$	conditional probability that the system is at state (m_1, m_2) given a successful transmission

words, the MAC sub-layer service time distribution plays an important role in the analysis and/or provisioning of packet-level QoS (such as throughput, delay, jitter, loss rate, and fairness) and call-level QoS (such as call blocking probability) from the viewpoint of the network layer and beyond.

The service time distribution of IEEE 802.11 DCF and EDCA is investigated in [8]-[14], based on analytical methodology and results in Bianchi's model [15]. However, our distributed MAC has a backoff procedure (as indicated in Section II) different from DCF and EDCA, which makes a model based on Bianchi's work not applicable to our scheme. Thus a different analytical model is needed. In this paper, we present a theoretical analysis of the service time distribution for the saturated case of our MAC scheme in [7].

The rest of this paper is organized as follows. The system model is given in Section II. The node service time distribution and system service time distribution are derived in Sections III and IV, respectively. Here the node service time and system service time refer to the duration between two consecutive successful packet transmissions from a particular node and from any nodes (in the system), respectively. Generally the node service time analysis decouples a node from the system with shared channel access, and indicates what services can be received at a single node. On the other hand, the system service time analysis gives the time-domain statistics of the system capacity. The performance evaluation is given in Section V, followed by concluding remarks in Section VI. As

many symbols are used in this paper, Table I summarizes the important ones.

II. SYSTEM MODEL

Our distributed MAC scheme can be described as follows. Consider a fully-connected network with a number of traffic classes. Similar to the EDCA, a higher-priority traffic class is assigned a smaller AIFS value. Without loss of generality, class 1 traffic has the highest priority with the smallest AIFS value, AIFS(1).

In both EDCA and our MAC scheme, each node's backoff timer is randomly selected from the range $[1, CW + 1]$, where CW is the node's current contention window size. In the EDCA, once a node senses the channel being idle for an AIFS of its traffic class, it starts to count down its backoff timer by one if the channel continues to be idle for one more slot. When the backoff timer reaches 0, the node transmits its packet. In our MAC scheme, once a node senses the channel being idle for an AIFS of its traffic class, it sends a black-burst (i.e., pulses of energy) [16] to jam the channel, the length of which (in the units of slot time) is equal to its backoff timer, as shown in Fig. 1. The node then senses the channel after its black-burst. If the channel is idle, the node transmits its packet; otherwise, the node defers its transmission by keeping the same contention window, selecting a new backoff timer, and waiting for the channel to be idle for its AIFS again. Our scheme has two properties: 1) only those nodes having the

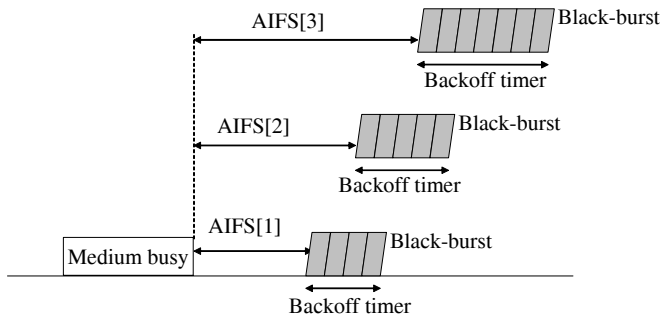

Fig. 1. The black-burst based MAC scheme [7].

smallest AIFS send a black-burst; and 2) among the nodes that send a black-burst, only the ones with the longest black-burst (or equivalently the largest backoff timer) transmit their packets.

The first property can provide guaranteed priority among different traffic classes. Consider the case of two nodes, node 1 with high priority and AIFS(1), and node 2 with low priority and AIFS(2). Assume that the channel is idle at instant t . Then nodes 1 and 2 are expected to sense the channel idle from t to $t + \text{AIFS}(1)$ and $t + \text{AIFS}(2)$, respectively, as shown in Fig. 2. At instant $t + \text{AIFS}(1)$, node 1 starts to transmit its black-burst. Node 2 hears the black-burst, and defers its transmission. So whenever there is a high-priority node, low-priority node cannot access the channel, and when a low-priority node transmits its black-burst, there should be no high-priority node. In this way, guaranteed priority can be achieved among different traffic classes by different AIFS values.

The second property can achieve enhanced fairness. In the EDCA, the nodes with the smallest backoff timer transmit. When a node transmits successfully, its contention window is reset to the initial value, and thus its chance to win the next contention is still large. When a packet transmission is collided with, the contention window of the source node is doubled (until the maximum value is reached), and thus its chance to win the next contention is small. On the contrary, the nodes with the largest backoff timer transmit in our scheme. Upon a successful transmission, the node's contention window is reset to the initial value, so that its chance to have the largest backoff timer among all the nodes and win the next contention is small. Upon a collision of its packet, the node's contention window is doubled, and so it has a large chance to have the largest backoff timer among all the nodes and win the next contention. This means that our scheme can distribute the channel access time more fairly (in a short term) to the contending nodes than the EDCA¹. Similar to the EDCA, if the number of transmission failures (e.g., due to collisions and/or poor channel quality) for a packet at a node

¹Although the node with the largest backoff timer transmits in our scheme (as opposed to a node having the shortest backoff timer in the EDCA), the approach does not cause a significant throughput degradation. It is because our scheme can adopt small CW_{\min} and CW_{\max} , say 3 and 15 respectively, with which 500 nodes can operate effectively, as shown in our previous work [7]. In addition, the EDCA is suggested to be used if guaranteed priority and enhanced short-term fairness are not the design objectives of the MAC protocol, since the EDCA can achieve a slightly higher overall throughput as demonstrated in our previous work.

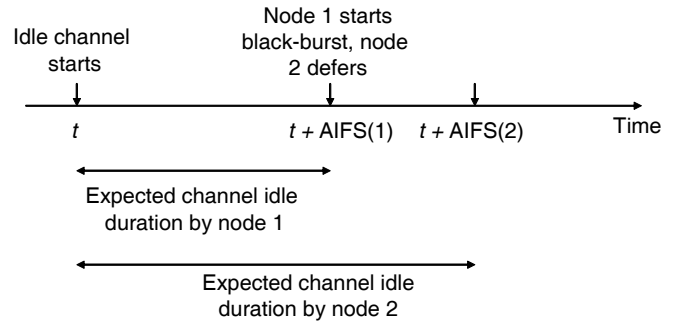

Fig. 2. Guaranteed priority in our MAC scheme.

is more than a threshold, the packet is discarded, and the contention window size is reset to the initial value CW_{\min} . This is effective for controlling packet delay, and also avoids the following problem of wasted resources. If a source node has a poor channel to its receiver, its transmissions will likely be unsuccessful. However, the source node cannot distinguish transmission errors due to collisions or due to a bad channel condition, and thus will double its contention window size. If the number of transmission attempts for a packet is not bounded, the node will get more and more chances to access the channel but will fail to have a successful transmission due to the bad channel condition, thus leading to wasted resources. In this paper, we consider only transmission errors due to collisions. However, the method in [17] can be easily incorporated into our analysis to address the case of a poor channel condition.

In the following we study the case with only one traffic class. The analysis for two or more traffic classes is our further research plan. In the network, a three-contention window setting is adopted. The contention window size of each node takes values from the set $\{CW_1, CW_2, CW_3\}$, where $CW_2 = 2 \cdot (CW_1 + 1) - 1$ and $CW_3 = 2 \cdot (CW_2 + 1) - 1$. In Section V, it will be seen that the probability of a node having contention window CW_3 is very small (as small as 4% in the example given there). Thus, when a setting of 4 or more contention windows $\{CW_1, CW_2, CW_3, CW_4, \dots\}$ is adopted, the probability of a node having contention window CW_4 or beyond will be much smaller, and is likely to be negligible for the analysis of the service time distribution. In our previous work [7], it has been demonstrated that the network throughput only changes slightly when the number of nodes in the network changes from 5 to 500, with a three-contention window setting $\{CW_1 = 3, CW_2 = 7, CW_3 = 15\}$. Therefore, the three-contention window setting works reasonably well for a very large number of nodes. This feature can facilitate network parameter setting, particularly when the network size is unknown in advance. It is quite different from the case in the DCF or EDCA, where the system performance is more or less sensitive to the number of nodes for a specific contention window setting. Therefore, we suggest that a three-contention window setting $\{CW_1 = 3, CW_2 = 7, CW_3 = 15\}$ be adopted in our scheme regardless of the network size, and present the performance analysis in the following.

III. NODE SERVICE TIME DISTRIBUTION

Consider N nodes in the network having IDs from 1 to N , and suppose that each node always has backlogged traffic to transmit. Node 1 is selected as the target node, for which we will get the node service time distribution. The derivation consists of two steps. The first step is to get the state distribution of the whole system. The second step is to obtain the state transition probabilities from the viewpoint of the target node, and to further obtain the node service time distribution.

A. State Distribution of the Whole System

Let C_t denote the contention window stage of the target node, i.e., $C_t = i \ (\in \{1, 2, 3\})$ means that the target node has a contention window CW_i . Let $n_1 \ (\leq N - 1)$ and $n_2 \ (\leq N - 1 - n_1)$ denote the numbers of the other $N - 1$ nodes (called *non-target nodes*) that have contention window CW_1 and CW_2 , respectively. Then the number of non-target nodes having contention window CW_3 is $n_3 = N - 1 - n_1 - n_2$. In the system, after all nodes complete their black-burst transmissions, a successful or a collided transmission will occur, which is referred to as an *event*. At the end of each event, we sample the vector (C_t, n_1, n_2) , and the evolution of this vector forms a Markov chain. We use state $(1, 1, 0)$ as an example for $N = 10$. In this state, the target node has contention window CW_1 , one of the non-target nodes (referred to as node 2) has contention window CW_1 , and other non-target nodes (nodes 3-10) have contention window CW_3 . After an event, the next state is $(1, 1, 0)$ if the target node or node 2 transmits successfully, $(1, 2, 0)$ if one of nodes 3-10 transmits successfully, $(2, 0, 1)$ if the target node and node 2 collide², $(2, 1, 0)$ if the target node collides with one or more nodes from nodes 3-10, $(1, 0, 1)$ if node 2 collides with one or more nodes from nodes 3-10, $(1, 1, 0)$ if two or more nodes from nodes 3-10 collide, and $(2, 0, 1)$ if the target node, node 2, and one or more nodes from nodes 3-10 collide. It can be seen that either a successful transmission or a collision may lead the state to remain the same at $(1, 1, 0)$.

In general, in state (C_t, n_1, n_2) , there may be one or more transmissions from all of the N nodes in an event. Here a transmission from a node means that the node has the largest backoff timer (thus the longest black-burst) among all the nodes and starts its information packet exchange dialogue after its black-burst. Define a transmission vector (x_t, x_1, x_2, x_3) , where $x_t \in \{0, 1\}$ is the number of transmission from the target node, and where $x_1 \ (\leq n_1)$, $x_2 \ (\leq n_2)$, and $x_3 \ (\leq n_3)$ are the number of transmissions from non-target nodes having contention window CW_1 , CW_2 , and CW_3 , respectively. Obviously when $x_t + x_1 + x_2 + x_3 = 1$, a successful transmission happens; when $x_t + x_1 + x_2 + x_3 > 1$, a collision occurs. Then after an event with transmission vector

(x_t, x_1, x_2, x_3) , the next state of (C_t, n_1, n_2) is given by

$$\left\{ \begin{array}{l} (C_t, n_1 + x_2 + x_3, n_2 - x_2), \\ \quad \text{if } x_t = 0 \text{ and } x_1 + x_2 + x_3 = 1 \\ (C_t, n_1 - x_1, n_2 + x_1 - x_2), \\ \quad \text{if } x_t = 0 \text{ and } x_1 + x_2 + x_3 > 1 \\ (1, n_1, n_2), \\ \quad \text{if } x_t = 1 \text{ and } x_1 + x_2 + x_3 = 0 \\ (\min[C_t + 1, 3], n_1 - x_1, n_2 + x_1 - x_2), \\ \quad \text{if } x_t = 1 \text{ and } x_1 + x_2 + x_3 > 0. \end{array} \right. \quad (1)$$

Let $p_{C_t, n_1, n_2; x_t, x_1, x_2, x_3}$ denote the probability of the transmission vector (x_t, x_1, x_2, x_3) at the next event, conditioned on the current state being (C_t, n_1, n_2) . We consider three cases to determine this probability.

1) If $x_1 \geq 1$, or $(C_t = 1 \text{ and } x_t = 1)$, at least one node with contention window CW_1 transmits. Then the largest backoff timer among all the nodes is in the range $[1, CW_1 + 1]$. The transmission vector probability is given by

$$\begin{aligned} p_{C_t, n_1, n_2; x_t, x_1, x_2, x_3} &= \sum_{i=1}^{CW_1+1} \left[\binom{1}{x_t} \left(\frac{1}{(CW_1 + 1) \cdot 2^{C_t-1}} \right)^{x_t} \right. \\ &\quad \cdot \left. \left(\frac{i-1}{(CW_1 + 1) \cdot 2^{C_t-1}} \right)^{1-x_t} \right] \\ &\quad \cdot \left[\binom{n_1}{x_1} \left(\frac{1}{CW_1 + 1} \right)^{x_1} \left(\frac{i-1}{CW_1 + 1} \right)^{n_1-x_1} \right] \\ &\quad \cdot \left[\binom{n_2}{x_2} \left(\frac{1}{CW_2 + 1} \right)^{x_2} \left(\frac{i-1}{CW_2 + 1} \right)^{n_2-x_2} \right] \\ &\quad \cdot \left[\binom{n_3}{x_3} \left(\frac{1}{CW_3 + 1} \right)^{x_3} \left(\frac{i-1}{CW_3 + 1} \right)^{n_3-x_3} \right]. \quad (2) \end{aligned}$$

Within the summation in (2), the first term is the probability that the target node has the largest backoff timer i if $x_t = 1$, or that the target node has a backoff timer less than i if $x_t = 0$; the second term is the probability that x_1 nodes from the n_1 non-target nodes with contention window CW_1 have the largest backoff timer i while the others from the n_1 nodes have a backoff timer less than i ; and so on.

The average time duration of the transmission(s) from the beginning of the black-burst(s) until the end of the information

²Note that when we say ‘‘two or more nodes collide,’’ we mean that the packets from the nodes collide.

packet exchange dialogue is given by³

$$t_{C_t, n_1, n_2; x_t, x_1, x_2, x_3} = T_x + t_{\text{slot}} \cdot \frac{1}{p_{C_t, n_1, n_2; x_t, x_1, x_2, x_3}} \cdot \sum_{i=1}^{CW_1+1} i \cdot \left[\binom{1}{x_t} \left(\frac{1}{(CW_1+1) \cdot 2^{C_t-1}} \right)^{x_t} \cdot \left(\frac{i-1}{(CW_1+1) \cdot 2^{C_t-1}} \right)^{1-x_t} \right] \cdot \left[\binom{n_1}{x_1} \left(\frac{1}{CW_1+1} \right)^{x_1} \left(\frac{i-1}{CW_1+1} \right)^{n_1-x_1} \right] \cdot \left[\binom{n_2}{x_2} \left(\frac{1}{CW_2+1} \right)^{x_2} \left(\frac{i-1}{CW_2+1} \right)^{n_2-x_2} \right] \cdot \left[\binom{n_3}{x_3} \left(\frac{1}{CW_3+1} \right)^{x_3} \left(\frac{i-1}{CW_3+1} \right)^{n_3-x_3} \right] \quad (3)$$

where t_{slot} is the slot duration, and T_x is the information packet exchange dialogue duration given by

$$T_x = \begin{cases} AIFS + t_{\text{RTS}} + t_{\text{CTS}} + t_{\text{DATA}} + t_{\text{ACK}} + 3SIFS, & \text{if } x_t + x_1 + x_2 + x_3 = 1, \text{ with RTS/CTS} \\ AIFS + t_{\text{RTS}} + t_{\text{CTS}_{\text{timeout}}}, & \text{if } x_t + x_1 + x_2 + x_3 > 1, \text{ with RTS/CTS} \\ AIFS + t_{\text{DATA}} + t_{\text{ACK}} + SIFS, & \text{if } x_t + x_1 + x_2 + x_3 = 1, \text{ no RTS/CTS} \\ AIFS + t_{\text{DATA}} + t_{\text{ACK}_{\text{timeout}}}, & \text{if } x_t + x_1 + x_2 + x_3 > 1, \text{ no RTS/CTS} \end{cases} \quad (4)$$

with t_{RTS} , t_{CTS} , t_{DATA} , and t_{ACK} being the duration of request-to-send (RTS), clear-to-send (CTS), DATA, and ACK frames, respectively, $SIFS$ the short interframe space, $t_{\text{CTS}_{\text{timeout}}}$ the CTS timeout value, and $t_{\text{ACK}_{\text{timeout}}}$ the ACK timeout value. On the right side of the equality in (3), the second term is the average duration of the longest black-burst in an event.

2) If $x_1 = 0$, and ($C_t = 1, x_t = 0, x_2 \geq 1$) or ($C_t = 2, x_t + x_2 \geq 1$) or ($C_t = 3, x_2 \geq 1$), no node with contention window CW_1 transmits, and at least one node with CW_2 transmits. In this case, the largest backoff timer among all the nodes is in the range $[1, CW_2 + 1]$. The transmission vector probability is given by

$$p_{C_t, n_1, n_2; x_t, x_1, x_2, x_3} = \sum_{i=1}^{CW_2+1} F_{C_t=1, i > CW_1+1} \left[1, \binom{1}{x_t} \left(\frac{1}{(CW_1+1) \cdot 2^{C_t-1}} \right)^{x_t} \cdot \left(\frac{i-1}{(CW_1+1) \cdot 2^{C_t-1}} \right)^{1-x_t} \right] \cdot F_{i > CW_1+1} \left[1, \binom{n_1}{x_1} \left(\frac{1}{CW_1+1} \right)^{x_1} \left(\frac{i-1}{CW_1+1} \right)^{n_1-x_1} \right] \cdot \left[\binom{n_2}{x_2} \left(\frac{1}{CW_2+1} \right)^{x_2} \left(\frac{i-1}{CW_2+1} \right)^{n_2-x_2} \right] \cdot \left[\binom{n_3}{x_3} \left(\frac{1}{CW_3+1} \right)^{x_3} \left(\frac{i-1}{CW_3+1} \right)^{n_3-x_3} \right] \quad (5)$$

³The time duration for a transmission is a variable. However, the random part (i.e., black-burst length) is much smaller than the fixed part (i.e., T_x) because the upper bound of the black-burst length in the unit of slot time is $(CW_{\text{max}} + 1)$ which can be selected to be very small (say $15+1=16$) as demonstrated in Section V. So we use the average time duration instead.

where the function $F_c[a, b]$ is

$$F_c[a, b] = \begin{cases} a & \text{if } c \text{ is true} \\ b & \text{if } c \text{ is false.} \end{cases} \quad (6)$$

The average time duration of the transmission(s) is given by

$$t_{C_t, n_1, n_2; x_t, x_1, x_2, x_3} = T_x + t_{\text{slot}} \cdot \frac{1}{p_{C_t, n_1, n_2; x_t, x_1, x_2, x_3}} \cdot \sum_{i=1}^{CW_2+1} i \cdot F_{C_t=1, i > CW_1+1} \left[1, \binom{1}{x_t} \left(\frac{1}{(CW_1+1) \cdot 2^{C_t-1}} \right)^{x_t} \cdot \left(\frac{i-1}{(CW_1+1) \cdot 2^{C_t-1}} \right)^{1-x_t} \right] \cdot F_{i > CW_1+1} \left[1, \binom{n_1}{x_1} \left(\frac{1}{CW_1+1} \right)^{x_1} \left(\frac{i-1}{CW_1+1} \right)^{n_1-x_1} \right] \cdot \left[\binom{n_2}{x_2} \left(\frac{1}{CW_2+1} \right)^{x_2} \left(\frac{i-1}{CW_2+1} \right)^{n_2-x_2} \right] \cdot \left[\binom{n_3}{x_3} \left(\frac{1}{CW_3+1} \right)^{x_3} \left(\frac{i-1}{CW_3+1} \right)^{n_3-x_3} \right]. \quad (7)$$

3) Otherwise, no node with contention window CW_1 or CW_2 transmits. The largest backoff timer among all the nodes is in the range $[1, CW_3 + 1]$. The transmission vector probability and the average duration of the transmission(s) can be obtained similarly.

From (1)-(7), we can obtain the transition probability matrix of the Markov chain with states (C_t, n_1, n_2) 's, and we can further obtain the steady state distribution, i.e., $\pi(C_t, n_1, n_2)$ for each state (C_t, n_1, n_2) .

B. State Transition Probabilities of the Target Node

Next we take the viewpoint of the target node. The probability of the target node being at a contention window stage i ($\in \{1, 2, 3\}$) is given by

$$P(C_t = i) = \sum_{n_1, n_2} \pi(C_t = i, n_1, n_2). \quad (8)$$

For the target node in the saturated case, its service time is the duration from the completion of a successful packet transmission (which leads its contention window size to the initial value CW_1) until the completion of its next successful packet transmission. We denote the completion of the previous successful packet transmission as state S . We also let A , B , and C denote the state that the target node has a contention window CW_1 , CW_2 , and CW_3 , respectively, at the end of an event. When the target node starts from state S , it immediately goes to state A , because the target node resets its contention window to CW_1 upon a successful transmission.

Starting from state A , after an event of the system (which may not associate with the target node), there are three possible results:

- The target node does not have the largest backoff timer among all the nodes, and thus it defers its transmission and its contention window size remains at CW_1 after the event of the system. Here the next state remains to be A ;
- The target node has the largest backoff timer among all the nodes, but its transmission is collided with, and thus

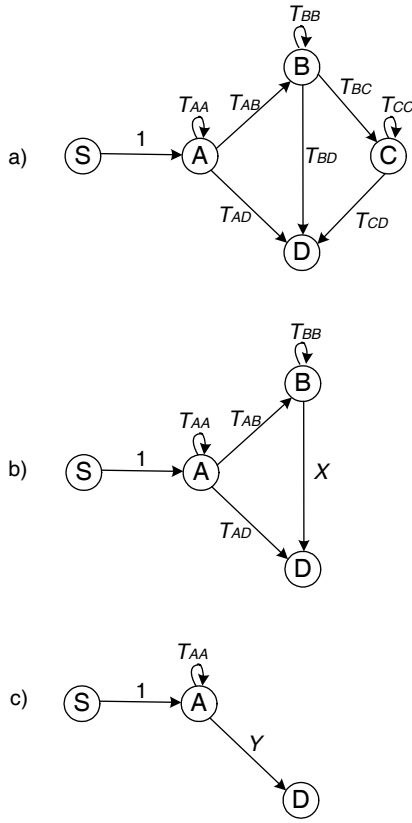

Fig. 3. The state transition diagram of the target node.

its contention window size is doubled (i.e., to CW_2). Here the next state is B ;

- The target node is the only node with the largest backoff timer, so that its transmission is successful, and its contention window size remains at CW_1 . Here we let D denote the state of a successful transmission of the target node⁴.

We denote the transition probability from state i to j as $p_{i,j}$, and the average time duration of the transition (i.e., the time including the black-burst and the information packet exchange in the event which leads state i to state j) as $t_{i,j}$ where $i, j \in \{S, A, B, C, D\}$. For such a transition, define a transition function

$$T_{ij}(Z) = p_{i,j}Z^{t_{i,j}}. \tag{9}$$

For simplicity of presentation, the variable Z is omitted from $T_{ij}(Z)$ in the remainder of this paper. Note that $T_{SA} = 1$ because state S is actually a sub-state of A .

We sample the state of the target node after each event of the system, and form the state transition diagram as shown in Fig. 3(a). The annotation beside a transition is the corresponding transition function. In this framework, the service time of the target node is the time to transit from state S to state D along any of the paths in the diagram. In the following, we first derive the probability and time duration of each transition in Fig. 3(a), and then we derive the distribution of the service time from state S to state D along any path.

⁴Although state D is actually a sub-state of A , it is used here for presentation simplicity.

The state A actually corresponds to a collection of states $(C_t = 1, n_1, n_2)$ of the system. Under the condition that the target node is in state A , the system is in state $(C_t = 1, n_1, n_2)$ with probability $\pi(C_t = 1, n_1, n_2)/P(C_t = 1)$. The state transition of the target node from A to A means the target node defers its transmission, i.e., $x_t = 0$. So we have

$$p_{A,A} = \sum_{n_1, n_2} \left[\frac{\pi(C_t = 1, n_1, n_2)}{P(C_t = 1)} \cdot \sum_{x_1, x_2, x_3} p_{C_t=1, n_1, n_2; x_t=0, x_1, x_2, x_3} \right] \tag{10}$$

and

$$t_{A,A} = \frac{1}{p_{A,A}} \sum_{n_1, n_2} \left[\frac{\pi(C_t = 1, n_1, n_2)}{P(C_t = 1)} \cdot \sum_{x_1, x_2, x_3} p_{C_t=1, n_1, n_2; x_t=0, x_1, x_2, x_3} \cdot t_{C_t=1, n_1, n_2; x_t=0, x_1, x_2, x_3} \right].$$

When the target node collides with one or more other nodes, i.e., $x_t = 1, x_1 + x_2 + x_3 \geq 1$, the next state from A should be B . So we have

$$p_{A,B} = \sum_{n_1, n_2} \left[\frac{\pi(C_t = 1, n_1, n_2)}{P(C_t = 1)} \cdot \sum_{x_1+x_2+x_3 \geq 1} p_{C_t=1, n_1, n_2; x_t=1, x_1, x_2, x_3} \right] \tag{11}$$

and

$$t_{A,B} = \frac{1}{p_{A,B}} \sum_{n_1, n_2} \left[\frac{\pi(C_t = 1, n_1, n_2)}{P(C_t = 1)} \cdot \sum_{x_1+x_2+x_3 \geq 1} (p_{C_t=1, n_1, n_2; x_t=1, x_1, x_2, x_3} \cdot t_{C_t=1, n_1, n_2; x_t=1, x_1, x_2, x_3}) \right]. \tag{12}$$

From state A , when the target node is the only one that transmits, i.e., $x_t = 1, x_1 = x_2 = x_3 = 0$, the next state from A is D . So we have

$$p_{A,D} = \sum_{n_1, n_2} \left[\frac{\pi(C_t = 1, n_1, n_2)}{P(C_t = 1)} \cdot p_{C_t=1, n_1, n_2; x_t=1, x_1=0, x_2=0, x_3=0} \right] \tag{13}$$

and

$$t_{A,D} = \frac{1}{p_{A,D}} \sum_{n_1, n_2} \left[\frac{\pi(C_t = 1, n_1, n_2)}{P(C_t = 1)} \cdot p_{C_t=1, n_1, n_2; x_t=1, x_1=0, x_2=0, x_3=0} \cdot t_{C_t=1, n_1, n_2; x_t=1, x_1=0, x_2=0, x_3=0} \right]. \tag{14}$$

Based on the above equations, we can obtain the transition functions T_{AA} , T_{AB} , and T_{AD} . Similarly, we can obtain other transition functions in Fig. 3(a).

By reduction of the flow graph in Fig.3(a), the equivalent graph of Fig.3(a) can be obtained as shown in Fig.3(b), where

$$X = T_{BD} + \frac{T_{BC}T_{CD}}{1 - T_{CC}} \tag{15}$$

with the denominator $(1 - T_{CC})$ due to the self-loop at state C [8] [18].

Similarly, we can obtain the equivalent graph of Fig.3(b) as shown in Fig.3(c), where

$$Y = T_{AD} + \frac{T_{AB}X}{1 - T_{BB}}. \quad (16)$$

From Fig.3(c), when there are a total of N nodes, the probability generating function of the service time of a successful transmission at a node (i.e., from S to D along any path) can be calculated as

$$\begin{aligned} Q_{\text{node}}(N) &= \frac{Y}{1 - T_{AA}} \\ &= \frac{T_{AD}}{1 - T_{AA}} + \frac{T_{AB}T_{BD}}{(1 - T_{AA})(1 - T_{BB})} \\ &\quad + \frac{T_{AB}T_{BC}T_{CD}}{(1 - T_{AA})(1 - T_{BB})(1 - T_{CC})}. \end{aligned} \quad (17)$$

Note that the node service time and the system service time (analyzed subsequently in the next section) are discrete in nature, because their components (i.e., black-burst duration and T_x) take discrete values. From the probability generating function of the node service time, its probability mass function (PMF) can be obtained [8], as can its cumulative distribution function (CDF), mean value, and standard deviation.

IV. SYSTEM SERVICE TIME

In this section we derive the system service time distribution. As a successful transmission may happen at any node, it is not feasible to obtain the system service time distribution from the behavior of a target node (as in the previous section). Alternatively, we investigate this distribution from the viewpoint of the whole system. The derivation consists of three steps: The first step is to derive the transition functions of the system; The second step is to get the distribution of the time duration from a specific state until a successful transmission; The final step is to obtain the distribution of the time duration from a successful transmission to the next, which is exactly the system service time.

A. Transition Functions

Consider N nodes, each with infinitely backlogged traffic. Let m_1 and m_2 denote the numbers of nodes having contention windows CW_1 and CW_2 , respectively. Then the number of nodes having contention window CW_3 is $m_3 = N - m_1 - m_2$. If we sample the value of (m_1, m_2) after each event of the system, a Markov chain can be formed, as shown in Fig. 4.

For an event, let (y_1, y_2, y_3) denote the transmission vector, where y_1, y_2 and y_3 are the numbers of transmissions from nodes having contention windows CW_1, CW_2 , and CW_3 , respectively. So when $y_1 + y_2 + y_3 = 1$, a successful transmission occurs; when $y_1 + y_2 + y_3 > 1$, a collision occurs. Then the next state after an event with transmission vector (y_1, y_2, y_3) is

$$\begin{cases} (m_1 + y_2 + y_3, m_2 - y_2) & \text{if } y_1 + y_2 + y_3 = 1 \\ (m_1 - y_1, m_2 + y_1 - y_2) & \text{if } y_1 + y_2 + y_3 > 1. \end{cases} \quad (18)$$

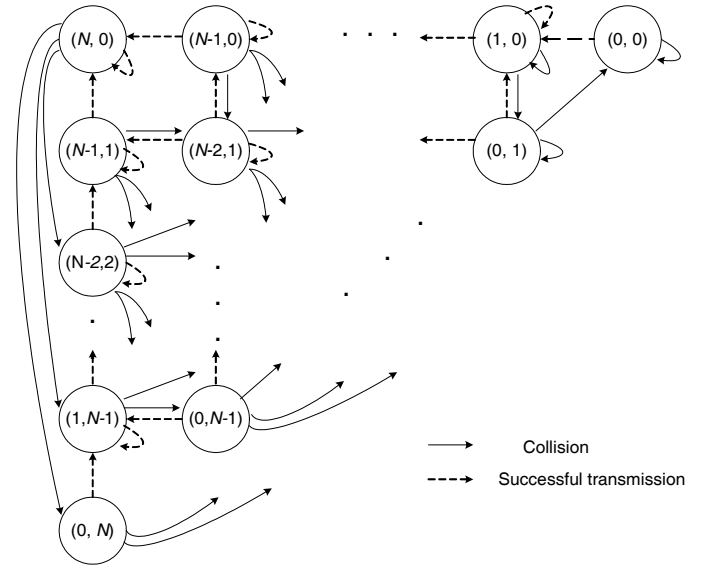

Fig. 4. The Markov chain with state (m_1, m_2) .

From state (m_1, m_2) , when $y_1 \geq 1$, at least one node with contention window CW_1 transmits. So the probability of the transmission vector (y_1, y_2, y_3) with the largest backoff timer value $i \in \{1, 2, \dots, CW_1 + 1\}$ at the next event, conditioned on the current state being state (m_1, m_2) , is given by

$$\begin{aligned} &p_{m_1, m_2; y_1, y_2, y_3}(i) \\ &= \left[\binom{m_1}{y_1} \left(\frac{1}{CW_1 + 1} \right)^{y_1} \left(\frac{i-1}{CW_1 + 1} \right)^{m_1 - y_1} \right] \\ &\quad \cdot \left[\binom{m_2}{y_2} \left(\frac{1}{CW_2 + 1} \right)^{y_2} \left(\frac{i-1}{CW_2 + 1} \right)^{m_2 - y_2} \right] \\ &\quad \cdot \left[\binom{m_3}{y_3} \left(\frac{1}{CW_3 + 1} \right)^{y_3} \left(\frac{i-1}{CW_3 + 1} \right)^{m_3 - y_3} \right]. \end{aligned} \quad (19)$$

When $y_1 = 0$ and $y_2 > 0$, the largest backoff timer i is in the range $[1, CW_2 + 1]$. Then we have

$$\begin{aligned} &p_{m_1, m_2; y_1, y_2, y_3}(i) = F_{i > CW_1 + 1} \left[1, \left(\frac{i-1}{CW_1 + 1} \right)^{m_1} \right] \\ &\quad \cdot \left[\binom{m_2}{y_2} \left(\frac{1}{CW_2 + 1} \right)^{y_2} \left(\frac{i-1}{CW_2 + 1} \right)^{m_2 - y_2} \right] \\ &\quad \cdot \left[\binom{m_3}{y_3} \left(\frac{1}{CW_3 + 1} \right)^{y_3} \left(\frac{i-1}{CW_3 + 1} \right)^{m_3 - y_3} \right]. \end{aligned} \quad (20)$$

When $y_1 = y_2 = 0$, the largest backoff timer i is within $[1, CW_3 + 1]$, and similarly we can get $p_{m_1, m_2; y_1, y_2, y_3}(i)$.

Similar to (9), the transition function of the transmission vector (y_1, y_2, y_3) is defined as

$$T_{m_1, m_2; y_1, y_2, y_3} = \sum_i p_{m_1, m_2; y_1, y_2, y_3}(i) \cdot Z^{T_x + i \cdot t_{\text{slot}}} \quad (21)$$

where T_x is given in (4).

B. Time Distribution from a Specific State until a Successful Transmission

Next we derive the probability generating function (denoted by Q_{m_1, m_2}) of the time from a state (m_1, m_2) to any state with

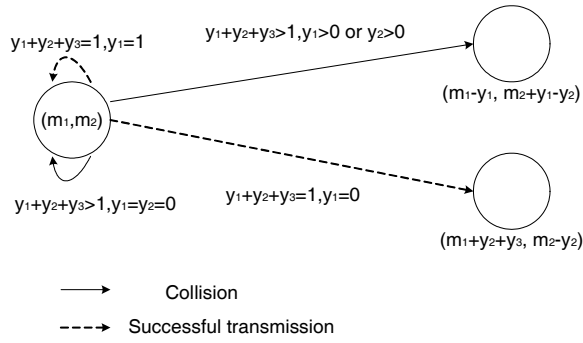
Fig. 5. The possible events resulting from state (m_1, m_2) .

a successful transmission. From state (m_1, m_2) , an event has three possible results, as shown in Fig. 5:

- When $y_1 + y_2 + y_3 > 1$ and $y_1 = y_2 = 0$ (or equivalently $y_1 = y_2 = 0$ and $y_3 > 1$), a collision happens and the next state remains at (m_1, m_2) ;
- When $y_1 + y_2 + y_3 > 1$, and $y_1 > 0$ or $y_2 > 0$ (i.e., $y_1 + y_2 > 0$), a collision happens and the next state changes to $(m_1 - y_1, m_2 + y_1 - y_2)$;
- When $y_1 + y_2 + y_3 = 1$, a successful transmission happens. If $y_1 = 0$, the next state is $(m_1 + y_2 + y_3, m_2 - y_2)$; otherwise (i.e., $y_1 = 1$), the state does not change.

Thus we have

$$\begin{aligned}
 Q_{m_1, m_2} &= \sum_{\substack{y_1+y_2+y_3 > 1, y_1+y_2 > 0}} T_{m_1, m_2; y_1, y_2, y_3} \cdot Q_{m_1-y_1, m_2+y_1-y_2} \\
 &\quad + \left[\sum_{y_3 > 1} T_{m_1, m_2; y_1=0, y_2=0, y_3} \right] \cdot Q_{m_1, m_2} \\
 &\quad + \sum_{y_1+y_2+y_3=1} T_{m_1, m_2; y_1, y_2, y_3} \quad (22)
 \end{aligned}$$

which leads to

$$\begin{aligned}
 Q_{m_1, m_2} &= \left(\sum_{\substack{y_1+y_2+y_3 > 1, y_1+y_2 > 0}} T_{m_1, m_2; y_1, y_2, y_3} \right. \\
 &\quad \cdot Q_{m_1-y_1, m_2+y_1-y_2} + \left. \sum_{y_1+y_2+y_3=1} T_{m_1, m_2; y_1, y_2, y_3} \right) / \\
 &\quad \left(1 - \sum_{y_3 > 1} T_{m_1, m_2; y_1=0, y_2=0, y_3} \right). \quad (23)
 \end{aligned}$$

Specifically, for state $(m_1 = 0, m_2 = 0)$, $y_1 = y_2 = 0$. Hence, we have

$$Q_{m_1=0, m_2=0} = \frac{T_{m_1=0, m_2=0; y_1=0, y_2=0, y_3=1}}{1 - \sum_{y_3 > 1} T_{m_1=0, m_2=0; y_1=0, y_2=0, y_3}}. \quad (24)$$

This means that $Q_{m_1=0, m_2=0}$ can be obtained directly based on (21). In order to obtain Q_{m_1, m_2} with $m_1 + m_2 > 0$, it can be seen from (23) that the values of $Q_{m_1-y_1, m_2+y_1-y_2}$ are needed. This suggests that we calculate Q_{m_1, m_2} values in the order of states $(0, 0)$, $(0, 1)$, ..., $(0, N)$, $(1, 0)$, $(1, 1)$, ..., $(1, N-1)$, ..., $(N-1, 0)$, $(N-1, 1)$, $(N, 0)$, as shown in Fig. 6.

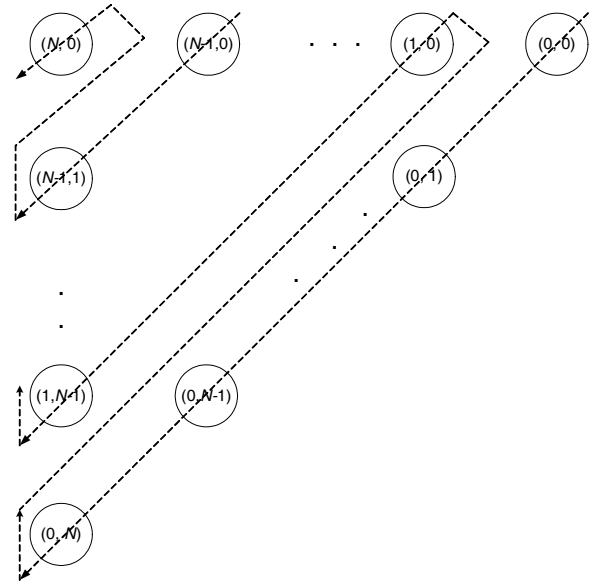
Fig. 6. The calculation order of Q_{m_1, m_2} for states (m_1, m_2) 's.

C. Distribution of the Time between Successful Transmissions

As the system service time is the duration from a successful transmission to the next successful transmission, in the following we first get the probability of the system being in a state of Fig. 4 when a successful transmission is completed, then we derive the system service time distribution, i.e., the distribution of the time duration between two adjacent successful transmissions.

Suppose the system is in state (m_1, m_2) . Let $P_{m_1, m_2; k_1, k_2}$ denote the conditional probability with which the system's first successful transmission leads the system to state (k_1, k_2) , given that the system starts from state (m_1, m_2) . An expression for $P_{m_1, m_2; k_1, k_2}$ is derived in the Appendix.

Given a successful transmission, we denote by $\psi(m_1, m_2)$ the conditional probability that the system is at state (m_1, m_2) . We have

$$\psi(m_1, m_2) = \sum_{i+j \leq N} \psi(i, j) \cdot P_{i, j; m_1, m_2}, \quad \text{for } m_1 + m_2 \leq N. \quad (25)$$

Based on (25) for all (m_1, m_2) values and $\sum_{m_1+m_2 \leq N} \psi(m_1, m_2) = 1$, we can obtain the steady state conditional probability $\psi(m_1, m_2)$ for any state (m_1, m_2) .

Then the probability generating function of the system service time is given by

$$Q_{\text{system}}(N) = \sum_{m_1+m_2 \leq N} \psi(m_1, m_2) \cdot Q_{m_1, m_2}. \quad (26)$$

Based on the probability generating function, we can obtain the PMF, CDF, mean, and standard deviation of the system service time.

V. PERFORMANCE EVALUATION

To verify the theoretical analysis of the preceding sections, we have run computer simulations using Matlab. In these simulations, the RTS/CTS dialogue is adopted in the distributed MAC scheme. Simulation parameter values are listed

TABLE IV
MEAN AND STANDARD DEVIATION (STD) (UNIT: MS) OF THE NODE AND SYSTEM SERVICE TIMES.

Number of nodes		2	4	6	8	10	16	20	
Node service time	Mean	Analysis	2.58	5.60	8.77	11.94	15.05	24.10	30.06
		Sim	2.57	5.61	8.77	11.93	15.02	24.09	30.04
	Std	Analysis	1.70	3.98	6.38	8.87	11.40	18.99	24.09
		Sim	1.52	3.85	6.34	8.90	11.54	18.98	24.01
System service time	Mean	Analysis	1.29	1.40	1.47	1.50	1.51	1.51	1.51
		Sim	1.29	1.40	1.46	1.49	1.50	1.51	1.50
	Std	Analysis	0.34	0.41	0.45	0.46	0.47	0.47	0.47
		Sim	0.34	0.42	0.45	0.47	0.47	0.48	0.48

TABLE II
SYSTEM PARAMETERS USED IN NUMERICAL ANALYSIS AND SIMULATIONS.

Parameter	Value	Parameter	Value
Highest rate	11 Mbps	Basic rate	2 Mbps
Slot time t_{slot}	20 μs	MAC header	34 bytes
AIFS	40 μs	Physical layer preamble	192 μs
SIFS	10 μs	DATA payload size	100 bytes
RTS	20 bytes	CTS	14 bytes
ACK	14 bytes	$CW_1 : CW_2 : CW_3$	3:7:15

TABLE III
PROBABILITY DISTRIBUTION OF THE CONTENTION WINDOW SIZE.

Contention window size	3	7	15
Analysis (%)	79.55	16.77	3.68
Simulation (%)	79.60	16.73	3.67

in Table II, where the highest rate is to transmit DATA and ACK frames, while the basic rate is to transmit RTS and CTS frames. For each simulation, the simulated channel time is 50 seconds, and statistics are collected over the last 40 seconds.

First we demonstrate that the setting of three contention window sizes (i.e., 3, 7, and 15) used in our analysis is reasonable. Consider 20 nodes with infinitely backlogged traffic. Table III shows the probability of a node having a given contention window size. Both analytical and simulation results indicate that a node has contention window size 15 with a very small probability, i.e., around 4%. Therefore, it is not necessary to adopt larger contention window sizes, and $CW_{max} = 15$ is sufficient.

Table IV shows the mean and standard deviation of the node service time and the system service time, when the number of nodes varies from 2 to 20. It can be seen that the analytical results match well with the simulation results. It is interesting to see that, when the number of nodes increases, the mean system service time approaches the value around 1.5 milliseconds (ms) and remains almost stable at the value. Actually, even when the node number increases to 50, both analysis and simulation results show that the mean system service time still remains at a value around 1.5 ms. This can be explained as follows. Consider a scenario in which all the nodes are with contention window CW_1 at the beginning. When N increases, an event is more likely to be a collision. However, more nodes are likely to be involved in the collision, and thus double their contention windows. These nodes are more likely to transmit successfully in subsequent contentions because they more likely select larger backoff timers (from larger contention windows). Therefore, the high collision probability at the beginning is compensated by a

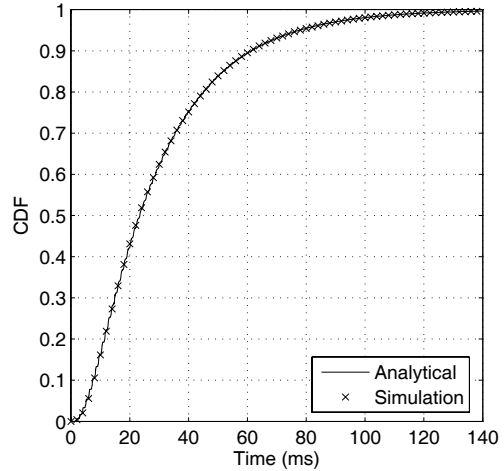

Fig. 7. The CDF of node service time when the number of nodes is 20.

larger number of subsequent successful transmissions, which causes the mean system service time to stay around the same value. This property follows from the fact that nodes benefit from collisions in following contentions. This observation can also be supported by Fig. 8 in our previous work [7], where the system throughput almost stays constant when the number of data nodes increases at contention window size setting $(CW_1 : CW_2 : CW_3) = (3:7:15)$. So the system service time is seen to be insensitive to the number of nodes when the number is larger than 6.

Figs. 7 and 8 show the CDF of the node service time and the system service time (i.e., the probability of the service time not larger than the value on the horizontal axis), respectively, for the case of 20 nodes. A close match between the analysis and simulation results is observed in these figures. From Fig. 8, the system service time is around 1.1 ms with a probability approximately 68%. In fact, the service time value is approximately the time for an RTS-CTS-DATA-ACK dialogue. Hence, it happens with a probability approximately 68% that the next event following a successful transmission is another successful transmission. The system service time is around 1.8 ms (the time for a collision and a successful transmission, i.e., an RTS-CTS_timeout and an RTS-CTS-DATA-ACK) with probability approximately 25%, and is around 2.5 ms (the time for 2 collisions and a successful transmission) with probability approximately 7%.

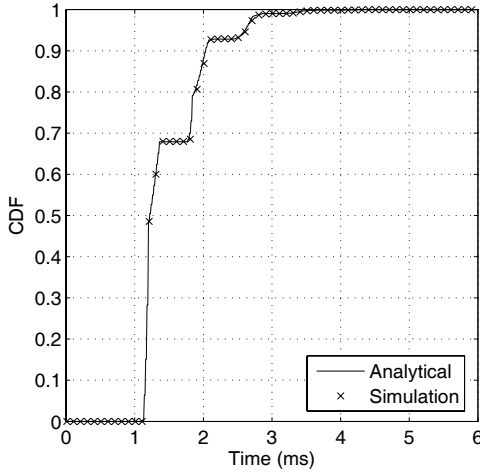

Fig. 8. The CDF of system service time when the number of nodes is 20.

VI. CONCLUSIONS

In this paper, we have analyzed a distributed MAC scheme for wireless multimedia networks, which has essential features of guaranteed priority and enhanced fairness to support real-time traffic (in terms of timely delivery) and non-real-time traffic (in terms of end-to-end transport layer performance). In particular, we have derived the distributions of the service time seen by a single node and by the overall system, respectively. The results on the service times should provide insights to the derivation of an admission region of the network with QoS (in terms of parameters such as the statistical delay bound⁵, packet dropping rate, and throughput), and to the development of an effective call admission control algorithm.

Interesting issues for further work include the analysis for the unsaturated case. From the results of unsaturated case with one traffic class, the service time analysis for the cases of two or more traffic classes can be obtained based on priority queueing theory.

APPENDIX: DERIVATION OF $P_{m_1, m_2; k_1, k_2}$

We define an L -element probability vector

$$\mathbf{P}_{m_1, m_2} = \{P_{m_1, m_2; 0,0}, P_{m_1, m_2; 0,1}, \dots, P_{m_1, m_2; 0,N}, \\ P_{m_1, m_2; 1,0}, \dots, P_{m_1, m_2; 1,N-1}, \dots, P_{m_1, m_2; N,0}\}$$

where $L = \frac{(N+2)(N+1)}{2}$ is the number of states in Fig. 4. In the vector, the position of element $P_{m_1, m_2; k_1, k_2}$ is

$$f(k_1, k_2) = \sum_{i=0}^{k_1-1} (N+1-i) + k_2 + 1 \\ = (N+1)k_1 - \frac{k_1(k_1-1)}{2} + k_2 + 1. \quad (27)$$

⁵As an example, a method is provided in [12] to derive the probability of the queuing delay larger than a delay bound, given the probability generating function of the service time in an M/G/1 queue.

From Fig. 5, we have

$$\mathbf{P}_{m_1, m_2} \\ = \sum_{y_1+y_2+y_3>1} \left(\mathbf{P}_{m_1-y_1, m_2+y_1-y_2} \sum_i p_{m_1, m_2; y_1, y_2, y_3}(i) \right) \\ + \sum_{y_1+y_2+y_3=1} \left(\mathbf{I}_{f(m_1+y_2+y_3, m_2-y_2)} \sum_i p_{m_1, m_2; y_1, y_2, y_3}(i) \right) \quad (28)$$

where \mathbf{I}_j is an L -element vector with the j th element being unity and other elements being zero.

Specifically for state $(m_1 = 0, m_2 = 0)$, we have $y_1 = y_2 = 0$. Then

$$\mathbf{P}_{m_1=0, m_2=0} \\ = \mathbf{P}_{m_1=0, m_2=0} \sum_{y_3>1} \sum_i p_{m_1=0, m_2=0; y_1=0, y_2=0, y_3}(i) \\ + \mathbf{I}_{f(1,0)} \sum_i p_{m_1=0, m_2=0; y_1=0, y_2=0, y_3=1}(i). \quad (29)$$

This leads to

$$\mathbf{P}_{m_1=0, m_2=0} \\ = \frac{\mathbf{I}_{f(1,0)} \sum_i p_{m_1=0, m_2=0; y_1=0, y_2=0, y_3=1}(i)}{1 - \sum_{y_3>1} \sum_i p_{m_1=0, m_2=0; y_1=0, y_2=0, y_3}(i)} \\ = \mathbf{I}_{f(1,0)} \quad (30)$$

which does not depend on other probability vectors \mathbf{P}_{m_1, m_2} with $m_1 + m_2 > 0$.

Equation (28) suggests that \mathbf{P}_{m_1, m_2} for all (m_1, m_2) values can be calculated along the direction shown in Fig. 6, starting from state $(m_1 = 0, m_2 = 0)$.

REFERENCES

- [1] I. F. Akyildiz, X. Wang, and W. Wang, "Wireless mesh networks: A survey," *Computer Networks*, vol. 47, no. 4, pp. 445–487, Mar. 2005.
- [2] H. Jiang, P. Wang, W. Zhuang, and X. Shen, "An interference aware distributed resource management scheme for CDMA-based wireless mesh backbone," *IEEE Trans. Wireless Commun.*, vol. 6, no. 12, pp. 4558–4567, Dec. 2007.
- [3] IEEE 802.11 WG, IEEE 802.11e/D11, "IEEE Standard for information technology-Telecommunications and information exchange between systems-Local and metropolitan area networks-Specific requirements-part 11: Wireless Medium Access Control (MAC) and Physical Layer (PHY) specifications: Amendment 7: Medium Access Control (MAC) Quality of Service (QoS) Enhancements," Oct. 2004.
- [4] X. Yang and N. H. Vaidya, "Priority scheduling in wireless ad hoc networks," in *Proc. 3rd ACM Int'l Symp. Mobile Ad Hoc Networking and Computing (MobiHoc'02)*, pp. 71–79, Lausanne, Switzerland, June 2002.
- [5] J. W. Robinson and T. S. Randhawa, "Saturation throughput analysis of IEEE 802.11e enhanced distributed coordination function," *IEEE J. Select. Areas Commun.*, vol. 22, no. 5, pp. 917–928, June 2004.
- [6] C. E. Koksal, H. Kassab, and H. Balakrishnan, "An analysis of short-term fairness in wireless media access protocols," *ACM SIGMETRICS Performance Evaluation Review*, vol. 28, no. 1, pp. 118–119, June 2000.
- [7] H. Jiang, P. Wang, and W. Zhuang, "A distributed channel access scheme with guaranteed priority and enhanced fairness," *IEEE Trans. Wireless Commun.*, vol. 6, no. 6, pp. 2114–2125, June 2007.
- [8] H. Zhai, Y. Kwon, and Y. Fang, "Performance analysis of IEEE 802.11 MAC protocols in wireless LANs," *Wireless Commun. and Mobile Computing*, vol. 4, no. 8, pp. 917–931, Dec. 2004.
- [9] A. Abdrabou and W. Zhuang, "Service time approximation in IEEE 802.11 single-hop ad hoc networks," *IEEE Trans. Wireless Commun.*, vol. 7, no. 1, pp. 305–313, Jan. 2008.
- [10] O. Tickoo and B. Sikdar, "Queueing analysis and delay mitigation in IEEE 802.11 random access MAC based wireless networks," in *Proc. IEEE INFOCOM*, pp. 1404–1413, Hong Kong, China, Mar. 2004.

- [11] A. Banchs, "Analysis of the distribution of the backoff delay in 802.11 DCF: A step towards end-to-end delay guarantees in WLANs", in *Proc. 5th International Workshop on Quality of future Internet Services (QoFIS'04)*, pp. 54–63, Barcelona, Spain, Sept. 2004.
- [12] P. Jacquet, A. M. Naimi, and G. Rodolakis, "Routing on asymptotic delays in IEEE 802.11 wireless ad hoc networks," in *Proc. 1st Workshop on Resource Allocation in Wireless NETWORKS (RAWNET'05)*, Riva Del Garda, Italy, Apr. 2005.
- [13] P. E. Engelstad and O. N. Osterbo, "Analysis of the total delay of IEEE 802.11e EDCA and 802.11 DCF," in *Proc. IEEE Int'l. Conf. Commun. (ICC)*, pp. 552–559, Istanbul, Turkey, June 2006.
- [14] J. W. Tantra, C. H. Foh, I. Tinnirello, and G. Bianchi, "Analysis of the IEEE 802.11e EDCA under statistical traffic," in *Proc. IEEE Int'l. Conf. Commun. (ICC)*, pp. 546–551, Istanbul, Turkey, June 2006.
- [15] G. Bianchi, "Performance analysis of the IEEE 802.11 distributed coordination function," *IEEE J. Select. Areas Commun.*, vol. 18, no. 3, pp. 535–547, Mar. 2000.
- [16] J. L. Sobrinho and A.S. Krishnakumar, "Quality-of-service in ad hoc carrier sense multiple access wireless networks," *IEEE J. Select. Areas Commun.*, vol. 17, no. 8, pp. 1353–1368, Aug. 1999.
- [17] H. Wu, Y. Peng, K. Long, S. Cheng, and J. Ma, "Performance of reliable transport protocol over IEEE 802.11 wireless LAN: analysis and enhancement," in *Proc. IEEE INFOCOM*, pp. 599–607, New York, USA, June 2002.
- [18] L. P. A. Robichaud, M. Boisvert, and J. Robert. *Signal Flow Graphs and Applications*. Englewood Cliffs, NJ: Prentice-Hall, 1962.



Hai Jiang (S'04-M'07) received the B.S. degree in 1995 and the M.S. degree in 1998, both in electronics engineering, from Peking University, China and the Ph.D. degree (with an Outstanding Achievement in Graduate Studies Award) in 2006 in electrical engineering from the University of Waterloo, Canada. He was a Postdoctoral Fellow at the Department of Electrical Engineering, Princeton University from September 2006 to June 2007. Since July 2007, he has been an Assistant Professor at the Department of Electrical and Computer Engineering, University of Alberta, Canada. His research interests include radio resource management, cellular/WLAN interworking, and cross-layer design for wireless multimedia communications. He is an Associate Editor for IEEE TRANSACTIONS ON VEHICULAR TECHNOLOGY.



Ping Wang (M'08) received the BE and ME degrees from Huazhong University of Science and Technology, China, in 1994 and 1997, respectively, and the Ph.D. degree from the University of Waterloo, Ontario, Canada, in 2008, all in electrical engineering. She is currently an Assistant Professor in the School of Computer Engineering, Nanyang Technological University, Singapore. Her current research interests include QoS provisioning and resource allocation in multimedia wireless communications. She is a co-recipient of a Best Paper Award from IEEE ICC 2007. She is an Editor for International Journal of Ultra Wideband Communications and Systems.



positioning.

Weihua Zhuang (M'93-SM'01-F'08) received the B.Sc. and M.Sc. degrees from Dalian Maritime University, China, and the Ph.D. degree from the University of New Brunswick, Canada, all in electrical engineering. Since October 1993, she has been with the Department of Electrical and Computer Engineering, University of Waterloo, Canada, where she is a Professor. She is a co-author of the textbook *Wireless Communications and Networking* (Prentice Hall, 2003). Her current research interests include wireless communications and networks, and radio positioning. Dr. Zhuang is a co-recipient of a Best Paper Award from IEEE ICC 2007, a Best Student Paper Award from IEEE WCNC 2007, and the Best Paper Award from QShine 2007. She received the Outstanding Performance Award in 2005 and 2006 from the University of Waterloo for outstanding achievements in teaching, research, and service, and the Premier's Research Excellence Award (PREA) in 2001 from the Ontario Government for demonstrated excellence of scientific and academic contributions. She is the Editor-in-Chief of IEEE TRANSACTIONS ON VEHICULAR TECHNOLOGY, and an Editor of IEEE TRANSACTIONS ON WIRELESS COMMUNICATIONS, EURASIP JOURNAL ON WIRELESS COMMUNICATIONS AND NETWORKING, and INTERNATIONAL JOURNAL OF SENSOR NETWORKS.



H. Vincent Poor (S'72-M'77-SM'82-F'87) received the Ph.D. degree in EECS from Princeton University in 1977. From 1977 until 1990, he was on the faculty of the University of Illinois at Urbana-Champaign. Since 1990 he has been on the faculty at Princeton, where he is the Michael Henry Strater University Professor of Electrical Engineering and Dean of the School of Engineering and Applied Science. Dr. Poor's research interests are in the areas of stochastic analysis, statistical signal processing and their applications in wireless networks and related fields. Among his publications in these areas is the recent book *MIMO Wireless Communications* (Cambridge University Press, 2007).

Dr. Poor is a member of the National Academy of Engineering, a Fellow of the American Academy of Arts and Sciences, and a former Guggenheim Fellow. He is also a Fellow of the Institute of Mathematical Statistics, the Optical Society of America, and other organizations. In 1990, he served as President of the IEEE Information Theory Society, and in 2004-07 he served as the Editor-in-Chief of the IEEE TRANSACTIONS ON INFORMATION THEORY. Recent recognition of his work includes the 2005 IEEE Education Medal and the 2007 IEEE Marconi Prize Paper Award.