

# A “Systems Approach” to Design

With a Focus on Electronic Systems  
and a few asides...

# Scenarios

- There are two situations a designer will encounter:
  - There is a problem that requires a solution.
  - There is an idea which is in search of a problem.
- In industry, the former will be encountered most often and is the focus here.

# Formula for Design Success

Technical Knowledge  
+ Product Knowledge  
+ Experience  
+ Discipline  
+ Creativity  
+ Experimentation  
Solution

# Design Stages

1. Planning.
2. Proving.
3. Producing.

# Design Stages - Planning

1. Define the problem.
2. Categorize the solution.
3. Develop a system-level block diagram.
4. Select transducers.
5. Break down the electronics.
6. Create a schematic sketch.
7. Create a packaging plan.

# 1. Define the problem.

- State the problem in successively simpler terms.
- Ask questions. Be persistent.
- Take nothing for granted. Do not assume.
- Concentrate on solving the customer's problem.
- View the problem from the user's perspective.

**Mission Accomplished?**

## 2. Categorize the solution.

- This stage helps further define the problem and the path to the solution.
- There are three categories:
  1. A design already exists to solve the problem.
  2. An existing design could be modified to solve the problem.
  3. A design needs to be developed from scratch.

## 2. Categorization: Conceptual vs. Detailed Design

- Another way to view this stage prior to more detailed design is to consider solution *concepts*!
- There is almost always more than one way to achieve an objective: a conceptual design is a high-level idea that suggests an approach to solving the problem.
- It is important to consider all approaches, evaluate them, and then choose the best approach.
- Deriving the concepts involves *brainstorming*.

# 2. Categorization: Conceptual vs. Detailed Design

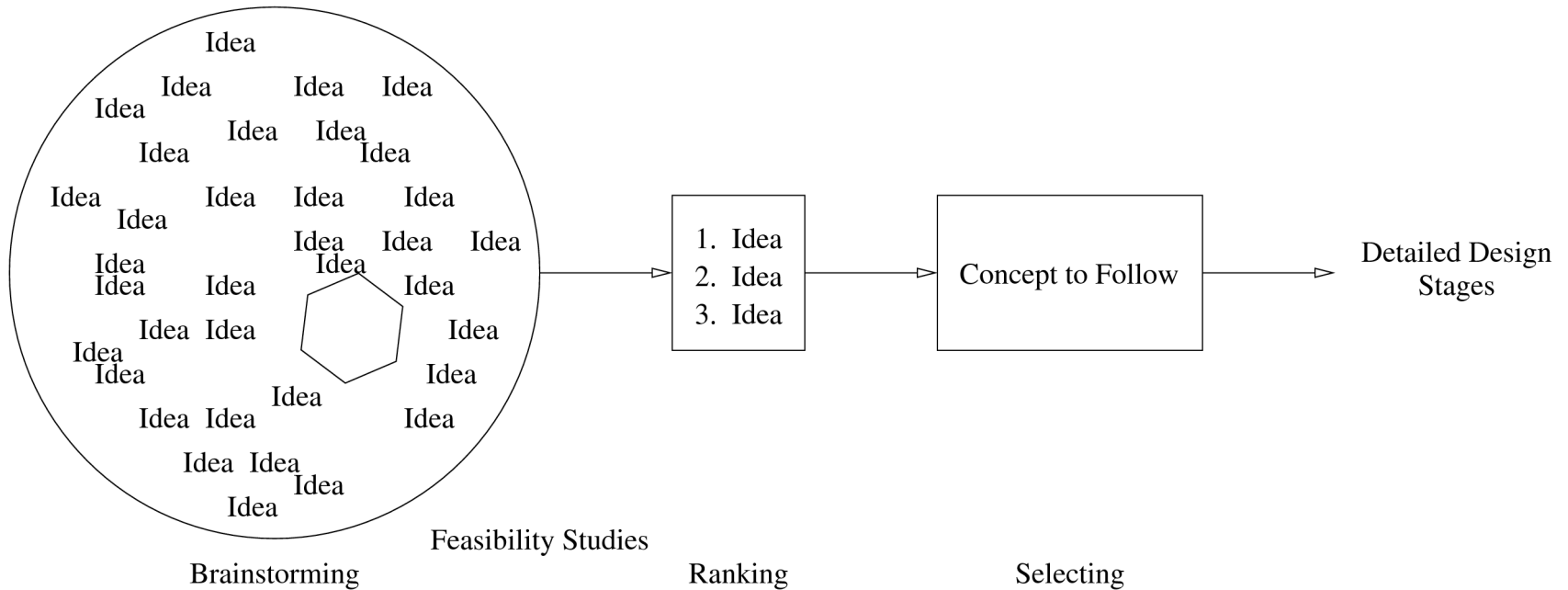

## 2. Categorization: Conceptual vs. Detailed Design

A common method used during the conceptual design stage is to

- a) come up with a myriad of ideas;
- b) rank the best three according to some preliminary feasibility analysis;
- c) presenting these to your client or supervisor; and
- d) collectively selecting the concept to follow.

Beware that your knowledge about the course and its requirements actually clutter this process!

### 3. Develop a system-level block diagram.

- Two methods:

**Top-Down Design:** start at a high-level of abstraction and “zoom in” to design at a more detailed level.

**Bottom-Up Design:** start at a detailed level and generalize until the entire system is designed.

- In practice, system design will likely involve some of each method.

### 3. Develop a system-level block diagram.

- The “Systems Approach” to design starts with a top-level block diagram:

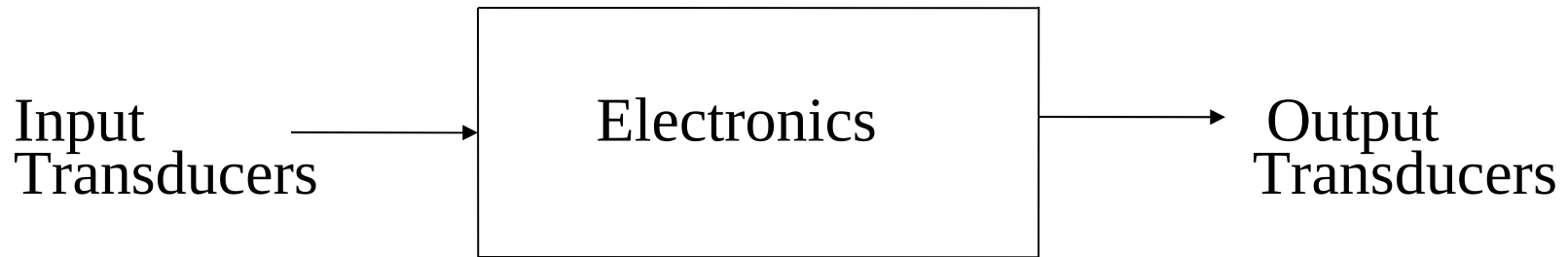

- Input and output transducers can also be other electronic systems.

### 3. Develop a system-level block diagram.

- On the input side, the transducer is usually called a “sensor”: strain gauge, microphone, etc.
- On the output side, the transducer is usually called an “actuator”: motor, solenoid, speaker, etc.
- Relaxing the definition of a “transducer”, it is possible to use the “systems” view to breakdown a large system into manageable pieces (subsystems).

## 4. Select transducers.

- This step may not be in the scope of the design (if they have already been selected).
- If it is in scope, selection depends heavily upon knowledge of existing products in the field.
- If not, characterization is required, perhaps through data sheets.

## 5. Break down the electronics.

- In this stage, the electronics of the system is described at a block diagram level.
- This stage depends heavily upon both technical and product knowledge.
- Show signal flow between the blocks.
- The blocks themselves are dictated by the field of design.

# Audio 3-Channel Equalizer

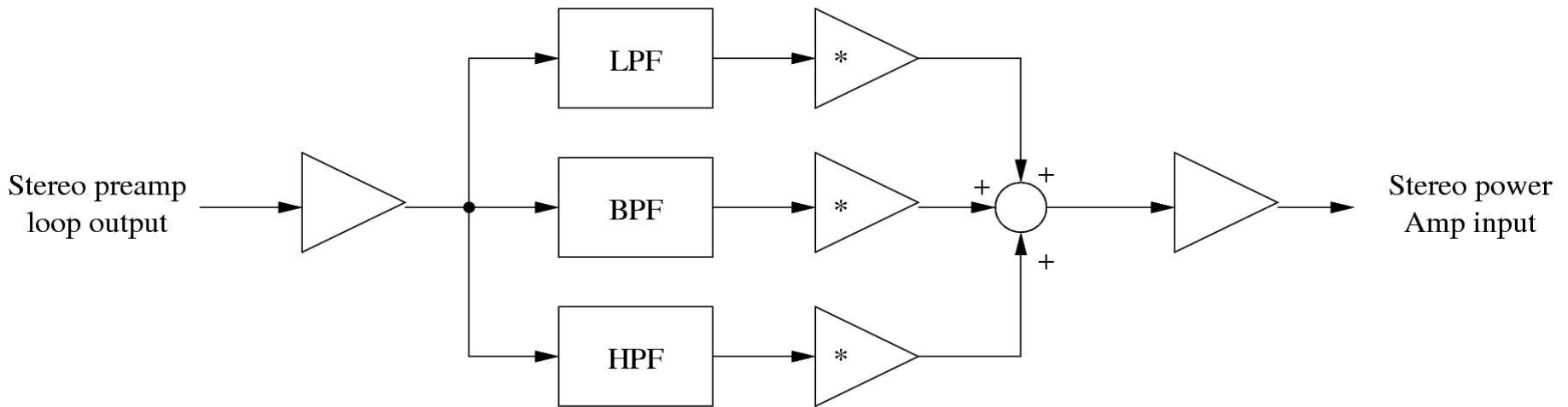

\*Amps have adjustable gain via slide potentiometers

## 6. Create a schematic sketch.

- In this stage, the block diagram is brought down to the electronic component level.
- The sketch is **not** the proven solution yet, but is based upon theoretical operation.
- The sketch provides something to discuss with peers.

## 7. Create a packaging plan.

- This shows how the product will look upon completion.
- Brings to light required functionality and perhaps shortcomings of the design.
- Provides motivation for completion of the design.

# Design Stages - Planning

- Breaking a system down into subsystems also lends itself to devising development milestones.
- For each subsystem:
  - Develop a circuit.
  - Develop a testing method (perhaps with software).
  - Assign responsibility.
  - Establish a completion time – a schedule!

# Design Stages - Planning

- The more thought and research that goes into each subsystem, the more accurately you'll be able to determine the amount of work and, thereby, the schedule of completion.

# Common Problems

- The design process can become cluttered by:
  - feature creep;
  - introduction or realization of different technologies during design; and
  - revised solution requirements.
- Be aware of these problems and their origins!

# Design Stages

1. Planning.
- 2. Proving.**
3. Producing.

Analysis + Analysis = Paralysis

Analysis + Action = Satisfaction

Action + Action = ?

# Design Stages - Proving

- Throughout the entire process of proving a design, a **working schematic drawing** must be maintained.
- Other drawings are often required, as suggested in the following steps.

# Design Stages - Proving

1. Simulate.
2. Breadboard.
3. Prototype.
4. Test.
5. Document the results.
6. Judge whether the project should proceed.

# 1. Simulate the design.

- Design verification using a computer is simple and inexpensive.
- For complex systems, emulators may be used to debug software components.
- Simulation software is typically included with schematic capture software.

## 2. Breadboard the design.

- A quick method of verifying circuit operation in the physical world.
- Simulation, although helpful, cannot detect all problems.
- Breadboarding methods:
  - breadboard
  - wire wrap
  - solderless circuit boards, etc.

## 2. Breadboarding (continued)

- If the design is complex, it is necessary to create a breadboard drawing which outlines component positions and connections.
- Many firms now skip this form of preliminary prototyping. Experience, simulation accuracy, cost, etc. would enter into the decision as to skip this stage or not!

### 3. Prototype the design.

- Construction method that results in a rugged circuit that is suitable for complete evaluation.
- Typically, this is a one-of-a-kind circuit board.
- Many PCB manufacturers offer a prototyping service to help with this stage.

# 3. Prototyping (continued)

- Many drawings may be required for the prototype:
  - component placement
  - artwork (copper foil, solder mask, silk screen)
  - fabrication
  - assembly
  - sheet metal
  - wiring
  - final packaging

### 3. Prototyping (continued)

- PCB layout software is often offered as part of the schematic capture/simulation package.
- There are many ways to create a prototype PCB.

## 4. Test the design.

- Evaluation of the design against the project requirements forms *operational* testing.
- This step is implemented throughout the proving of a design.
- Ensure that records are kept. A troubleshooting flowchart may form part of the design.

## 4. Test the design (continued)

- Exposing the design to “the treatment” from a user’s perspective forms *performance* testing.
- Impartiality is important.

## 5. Generate the “Test Results Document”.

- A record of the test and troubleshooting procedures.
- A record and summary of the test data collected.
- A dedicated document is not required in these courses, though there will be a corresponding section in the final report.

# 6. Generate the “Summary and Recommendations Document”

- Outlines where the project is at.
- Suggests what direction the project should take. There are four basic possibilities:
  - Production should be given consideration.
  - Further performance testing required.
  - Modifications required.
  - Failure due to unsatisfactory performance.
- Again, this document is not explicitly required in this course, but some of its contents will likely be found in the final report.

# Design Stages

1. Planning.
2. Proving.
- 3. Producing.**

# Design Stages - Producing

Production in mass of a successful design is a very large field unto itself and is not detailed here.

# Summary

- Structure to the design process is important.
- A paper trail is necessary as it spurs thoroughness.